



● **P250** ● **P450**

210°C to 3000°C

Features

- Wide temperature ranges: from 210°C to 3000°C.
- Spectral Range: 1.0 μm....1.6 μm
- Fast response time within milliseconds
- Through the Lens view finder sighting
- Focusable precision optics for adjusting the smallest spot size
- Temperature display in the view finder and on the multi function display
- Measuring Functions: Normal, Average , Maximum
- Standard USB Connectivity: USB Options for Communicating to PC
- Small Spot Sizes
- Large data storage for data analysis(Data storage upto 4000 values)
- Additionally the instruments are completed via large display and easy designed keypad for selecting and changing of all available functions and settings
- Numeric and Graphic LCD display on portable pyrometer
- User friendly PC software for communication

Standard Scope of Supply

- Pyrometer with through the lens sighting.
- USB interface, USB 2.0 Cable.
- Calibration certificate.
- Software CD and Operation manual.
- Carry Box
- Charger

Applications

- Welding
- Tempering
- Hardening
- Annealing
- Molten Glass
- Glass Moulds
- Steel
- Heater Tubes
- Reheat Furnaces

● **P250** ● **P450**

Highly Accurate Portable Infrared Non-Contact Pyrometer



P250 and P450 are specially designed portable IR pyrometer for non contact temperature measurement between 210°C to 3000°C in demanding industrial environments. The Instruments feature high accuracy.

The multi functional bright back light additional LCD graphic display panel provides an indication of status and configuration of pyrometer together with measurement mode. The measuring result is shown and can be analyzed directly on site. The bright through the lens sighting gives a precise definition of the target spot.

The portable pyrometer provides fast, simple data logging with USB connectivity to download this data to PC for analysis. The fast response time within milliseconds allow exact measurement of fast moving object.

The large data storage (data store upto 4000 values) of measurement offers the best possibility for analyzing the data.

Software “Infrasoft”

AST Infrasoft software is under standard scope of supply. It offer possible connection with PC for parameter setting, offline graph and to evaluate measuring data. Communication between the pyrometer and the PC is implemented via a USB cable connected between the pyrometer and the PC USB port.

Some of the parameter adjustable via software are :

- Emissivity
- Clear Time(Peak Picker)
- Unit of Temperature (°C/°F)



Technical Specifications

Model	P250	P450
Temperature Range	210°C....1350°C 250°C....1800°C 300°C....2500°C	600°C...2500°C 700°C... 3000°C
Spectral Range	1.6 μm	1.0 μm
Photodetector Type	InGaAs	Si
Distance to Spot Size Ratio	100:1 (210°C....1350°C) 200:1 (250°C....1800°C) 400:1 (300°C....2500°C)	400:1 (600°C...2500°C) 400:1 (700°C... 3000°C)
Emissivity (ε)	0.1....1.0 adjustable	
Response Time	5 msec in Numerical Mode 10 msec in Graphical Mode 10 msec (When data storage is 'ON')	
Accuracy	± 0.3% of the measured value + 1°C	
Repeatability	0.1% of reading in °C + 1°C	
Sighting Options	Optimized through lens view finder with dioptry correction -2.5 dpt. to +2.5 dpt	
Objective	Achromatic, adjustable from A=500 mm to 9000 mm Effective lens aperture diameter D:16mm (distance 9000mm) to 21 mm (distance 500mm)	
Measuring Functions	Normal (Normal Temperature Measurement) MAX (Maximum Temperature Measurement) AVG (Average Temperature Measurement)	
Parameters Setting Via Side Keypad	Emissivity, Peak Picker(Clear Time)(tCL), Average, Storage Interval, Temperature Unit (°C/°F), Auto Off Time, Date, Time	
Data Storage	4000 Values, Storage of Measurement Value, Date, Time, Emissivity	
Storage Interval	OFF, 10 msec, 20 msec, 100 msec, 1 sec, 10 sec, 100 sec, 500 sec	
Display	Left side: LCD Display, 128 x 64 pixels illuminated 3 value per sec.; last value is displayed for another 10 sec after finishing measurement (Hold Function) Additional Built in LED display in the view finder	
Resolution	LED inside : 0.1°C upto 1000°C after this 1°C, LCD outside : 0.1°C upto 1000°C after this 1°C	
Serial Interface	USB 2.0	
Alarm	Visual (LCD Blinking Facility)	
Mounting	Tripod	
Dimensions	228 x 64 x 186 mm (L x W x H)	
Weight	900g with batteries	
Housing	Aluminum, Handle: ABS	
Ambient Temperature	0 to 50°C	
Storage Temperature	-20 to 55°C	
Relative Humidity	10 - 95%, Non-Condensing Conditions	
Protection Class	IP52(Housing Exclude Handle with battery case), IP40 (Handle)	
Power Supply	3 x 1.2 V Rechargeable Batteries (uninterrupted operation time approx. 10 hours with rechargeable batteries)	
CE Label	According to EU Directives about electromagnetic immunity	

Optics

The pyrometers are equipped with a high quality focusable optics. Adjusting the optics to required measuring distance achieves the spot sizes specified in table. The adjustment can be taken via the scale on the objective or by focusing the measuring object in the view finder. User can adjust measuring distance from 500mm - 9000 mm.

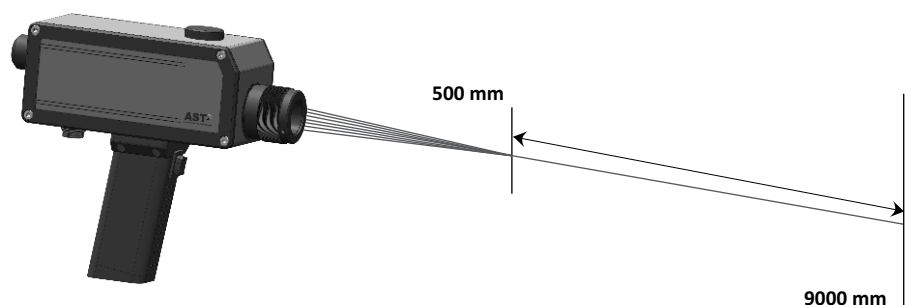

Measuring distances between 500 & 9000 mm with small spot sizes can be achieved with the pyrometers.

We measure accurate temperature in extreme conditions

Optical Specifications

Measuring Distances MD (mm) with standard focusable optics	Spot Sizes(mm)			
	P250 210°C - 1350°C (100:1)	P250 250°C - 1800°C (200:1)	P250 300°C - 2500°C (400:1)	P450 600°C - 2500°C 700°C - 3000°C (400:1)
500	2.5	2.5	2.5	2.5
1000	5.0	5.0	5.0	5.0
2000	10.0	10.0	10.0	10.0
3000	15.0	15.0	15.0	15.0
4000	20.0	20.0	20.0	20.0
5000	25.0	25.0	25.0	25.0
9000	45.0	45.0	45.0	45.0

Instruments Specifications

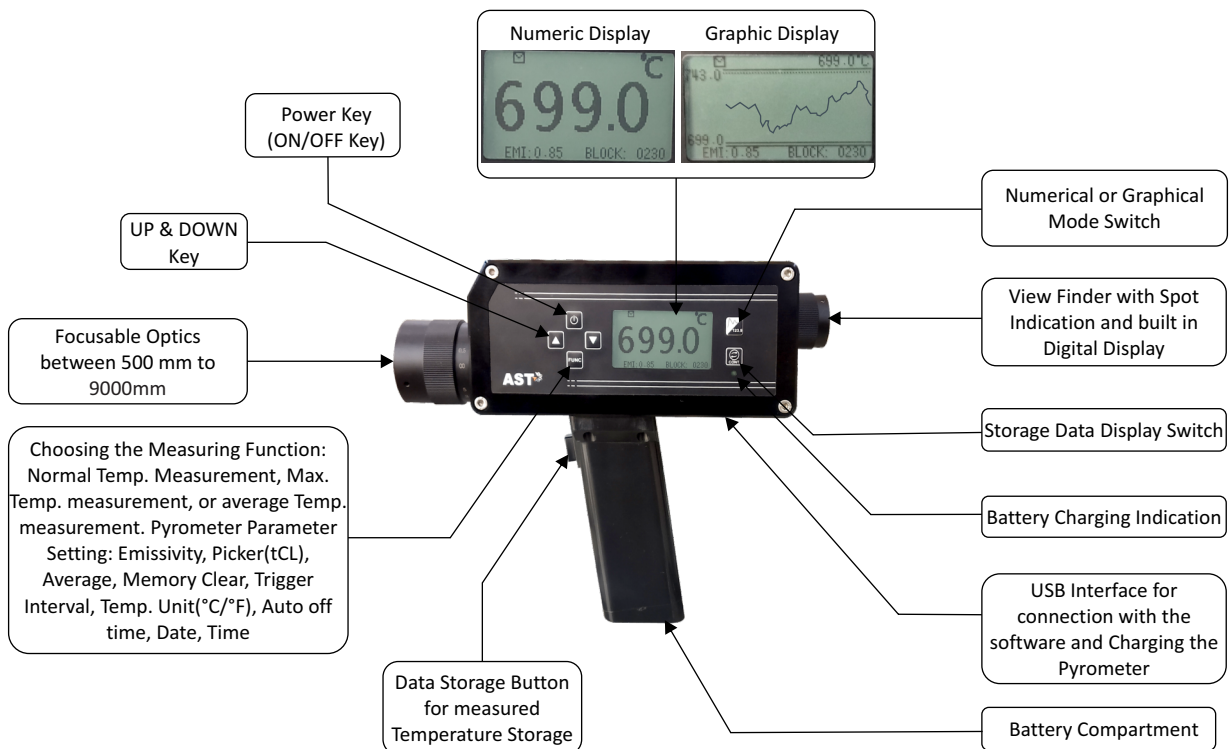

Pyrometer Drawings

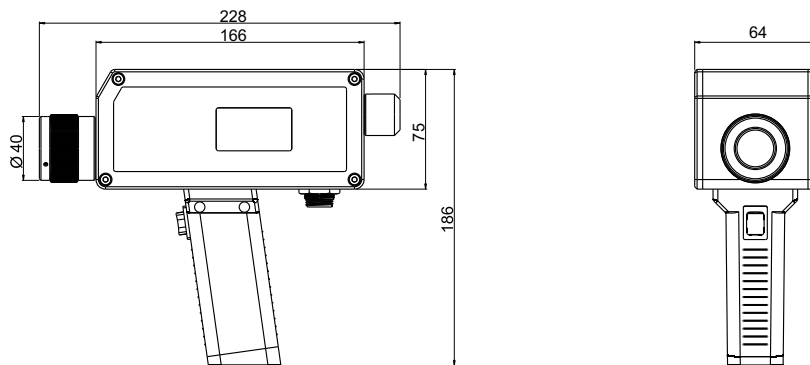

Accurate Sensors Technologies Pvt. Ltd.
 Misgav Industrial Park, Misgav 20174 Israel
Phone :+972-4-9990025, **Fax** : +972-4-9990031
E-mail : info@accuratesensors.com

Accurate Sensing Technologies Pvt. Ltd.
 188A, B-169 (Part), B-188 (A), Road No. - 5, M. I. A.,
 Madri, Udaipur (Rajasthan) - 313003
Phone : +91-9352506032
Email : sales@astinfrared.com

AST
 Accurate Sensors Technologies